

Fuel Tank Inlet (Filler) Cork (Plug) Position Sensor RFID Based.

Installation manual
Models: BAQ 60/BAQ 80

Technobaltica OU

Reg.12890134, Uuskula 19-76, 20204 Narva, Estonia EU
EUR VAT EE101816737

+372 5309 0819 info@technobaltica.com

All rights are reserved. ©2017 TECHNOBALTICA OU

TABLE OF CONTENTS

TABLE OF CONTENTS2

INTRODUCTION3

TECHNICAL DESCRIPTION.....4

 DESIGNATED USE4

 BAQ 60/80 TECHNICAL SPECIFICATION.....5

 STRUCTURE AND OPERATION.....5

ASSEMBLY AND USAGE6

 MECHANICAL SYSTEM.....6

 OPERATION MODULE ASSEMBLY.....6

 CABLE DESCRIPTION7

 CABLE CONNECTION.....7

 SAFETY MEASURES.....9

 OPERATION MANUAL.....9

STORAGE AND TRANSPORTATION 10

 STORAGE 10

 TRANSPORTATION..... 10

ACCESSORIES..... 11

 ANTI-SIPHON STRAINER..... 11

APPENDIX A 12

 GENERAL VIEW..... 12

APPENDIX B 13

 PLUG MODULE 13

APPENDIX C 14

 ANTI-SIPHON STRAINER..... 14

APPENDIX D 15

 CABIN SIGNALING MODULE 15

REVISION HISTORY 16

INTRODUCTION

BAQ fuel inlet cork (plug) position sensor RFID based model 60/80 (hereafter “BAQ 60/80”, numerical index represents diameter of a fuel inlet in millimeters) is a solution for comprehensive protection and monitoring of a vehicle fuel tank, which allows to eliminate fuel theft from tanks.

There are two ways of signal source connection: direct output from PLUG MODULE and high/low output from CABIN SIGNALING MODULE. Digital (discrete) input could be used in such case, to detect the presence/lack of signal and avoid tampering, such as cutting off the cable between PLUG MODULE/CABIN SIGNALING MODULES and AVL device.



THE MANUFACTURER RESERVES A RIGHT TO MODIFY THE DEVICE (WITHOUT ADVERSE EFFECT ON OPERATING AND MEASUREMENT PARAMETERS) WITHOUT MODIFYING THE CONTENT OF THIS OPERATION AND MAINTENANCE MANUAL.

TECHNICAL DESCRIPTION

Designated use

The plug module BAQ 60/80 controls and monitors fuel filler access on trucks, machinery, and construction equipment. As an option, it can be equipped with additional event signaling devices for the driver, anti-siphoning strainer is in a standard set.

The system is composed of two modules:

- BAQ 60/80 PLUG MODULE;
- CABIN SIGNALING MODULE;

They can also operate and be used as separate devices. PLUG MODULE and/or CABIN SIGNALING MODULE is connected to the monitoring system. CABIN SIGNALING MODULE has a preset number of elements for signaling events to the driver.

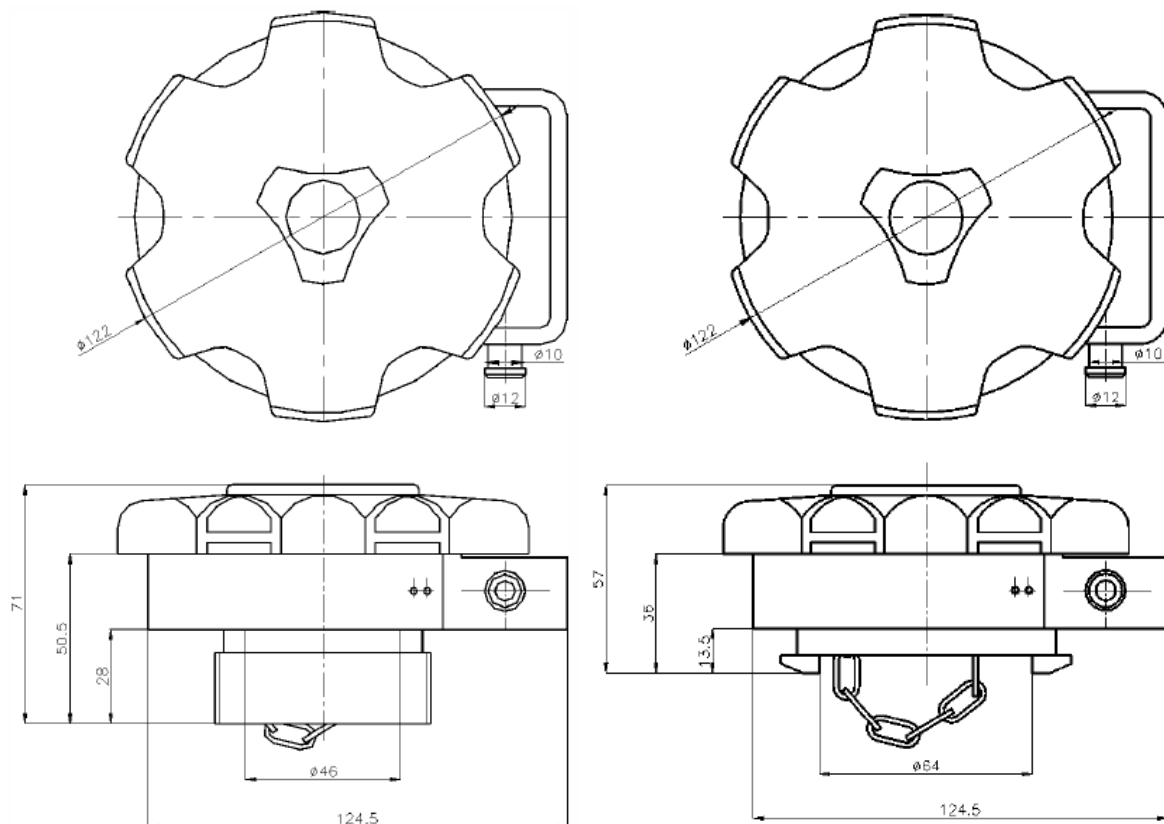

Figure 1. BAQ 60/80 dimensions.

BAQ 60/80 technical specification

Supply voltage:	16 - 32V DC, max 35V
Current draw:	35mA
Operation temperature:	-40...+80°C
Open Collector type signal parameters:	U_{\max} = VOLTAGE of power; I_{\max} =20 mA DC

Structure and operation

BAQ 60/80 both work by controlling the presence of the transponder, situated in the fuel plug, over the PLUG MODULE mounted in the tank's filler. The system interprets unscrewing the plug, as a change in output state or sabotage, cutting the cable through loss of signal on communication cord. The cord can be connected to the monitoring system and/or CABIN SIGNALING MODULE.

The CABIN SIGNALING MODULE notifies of the plug having been unscrewed (the cable having been cut - sabotage) with a LED diode and a beeper in the driver's cabin. It can be connected to the monitoring system that records all events. Optionally, CABIN SIGNALING MODULE operates with SILENT OPENING feature (unscrewing the plug is not signaled with a beep in the cabin) and ALERT MEMORY feature (information of unscrewing the plug is stored when the driver is not present in the cabin).

CABIN SIGNALING MODULE generates two types of signals for unscrewing the plug: normal opening (NO) and normal closing (NC) connection.

All signals are generated in OC type (opened collector).

ANTI-THEFT STRAINER MODULE is an integral part of PLUG MODULE and is mounted during production.

ASSEMBLY AND USAGE

Mechanical system

- Unscrew the original plug from the fuel filler.
- Degrease the tank fuel filler and the flange of PLUG MODULE using a cloth supplied in the assembly kit.
- Put silicone glue on to the fuel filler and the flange of PLUG MODULE
- Put a seal onto the flange of PLUG MODULE
- Mount PLUG MODULE with seal on to the fuel filler, turn the screw to the right until it is tightly screwed. It is recommended to use a flange in order to prevent the cable from sticking outside the vehicle.
- Drill an Ø4 mm bore carefully through the mounting holes in the filler.
- Put the mounting sleeve onto the removable rivet and place it in the riveter. Rivet both wholes.
- The cord must be protected with PROTECTIVE PIPE, which needs to be tightened on the flange of PLUG MODULE housing. Use a tie-rib. Guide the cable to the driver's cabin in such a way as to minimize all possible thermal and mechanical damage resulting from day-to-day use of the vehicle.
- Thread the seal line with bead through the seal holes; tie it around the PROTECTIVE PIPE. Seal it.
- Put silicone glue into the mounting wholes and push the rubber caps inside.
- Cut away the protruding cap parts.
- Screw the plug on the PLUG MODULE, unscrew and screw the plug again a few times in order to check the quality of PLUG MODULE assembly onto the fuel tank.

Operation module assembly

- Screw the supplied plug tightly on PLUG MODULE housing. Unscrew and screw the plug again a few times in order to check the quality of PLUG MODULE assembly onto the fuel tank and check the tightness of the safety screws.
- The CABIN SIGNALING MODULE should be mounted under the dashboard in the driver's cabin.
- Choose a proper location for the device to be mounted, minimizing the risk of any possible damage resulting from day-to-day use of the vehicle and taking into consideration all signals necessary to mount the device properly.
- The beeper must be mounted close to the top of the dashboard.
- Mount the beeper by hitching its cables to another group of electrical cables of the vehicle, using assembly clips.
- The LED signal diode must be mounted in a visible place on the dashboard of the vehicle by drilling a $\phi 8$ mm whole.
- Mount the LED diode in the black plastic cover.
- Push the diode cover firmly into the drilled whole on the top side of the dashboard.

Cable description

Cabin signaling device module – colors:

- Blue- ground
- Red- +24V
- Black- + ignition
- White- input (signal from BAQ 60/80)
- Green- input (signal from BAQ 60/80)
- Yellow- output 1 OC type (high status when BAQ 60/80 closed)
- Brown- output 2 OC type (low status when BAQ 60/80 closed)

Plug module – colors:

- Black- ground
- Red- +24V
- Grey- OC type output

Cable connection

Plug module connection to external systems

- Because of universal nature of the signals, the Installer should adapt the connection to external system requirements. We recommend connecting the signal from PLUG MODULE to the 0/1 input that indicates each status change, or to „pulse” input which responds to presence or lack of pulse, thus enabling detection of sabotage – cutting the cable.

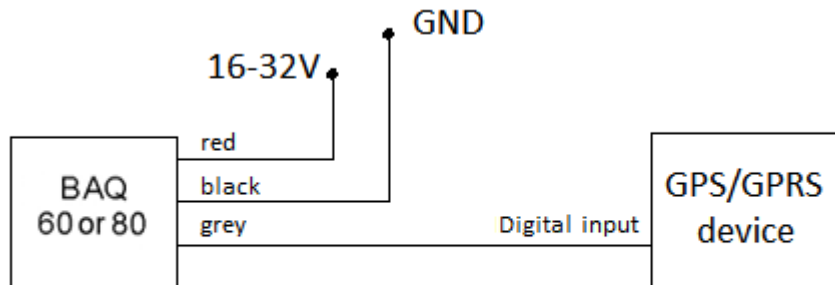

Figure 2. Connection scheme

Power cable connection

- Connect the +24V cable to positive voltage of the battery, connect the 'ground' cable to negative voltage of the battery.

Connecting plug module to cabin signaling device module

- Connect + ignition (power output behind the ignition lock) to the „black” cable from CABIN SIGNALING MODULE in order to use ALARM MEMORY function fully.

Single-tank set

Connect the 'grey' cable from PLUG MODULE in a fixed electrical connection to 'green' and 'white' from CABIN SIGNALING MODULE.

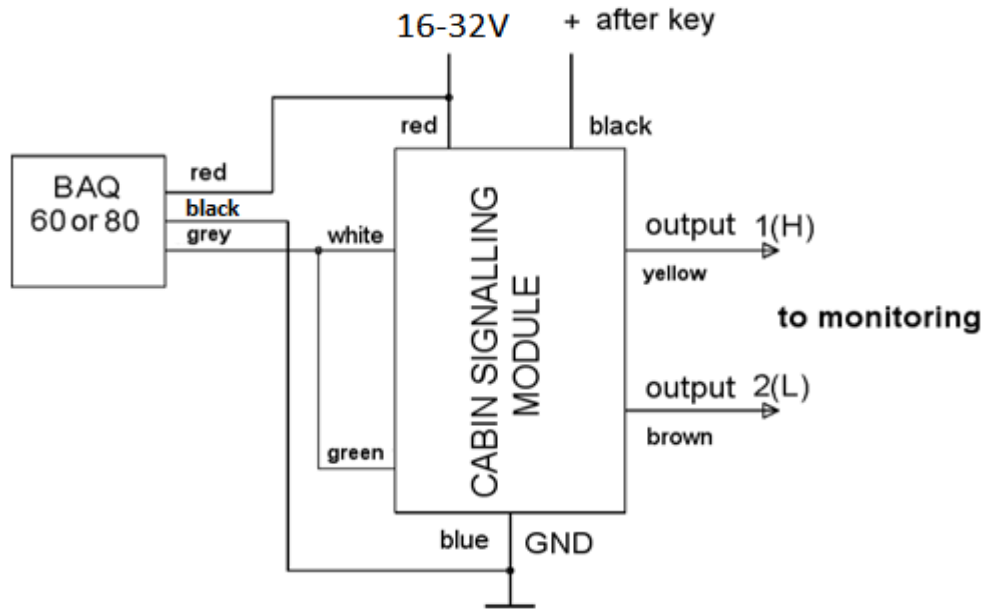

Figure 3. Single tank connection scheme.

Double-tank set

Connect the 'grey' cable from the first PLUG MODULE in a fixed electrical connection to 'green' cable from CABIN SIGNALLING MODULE. Connect the 'grey' cable from the second PLUG MODULE in a fixed electrical connection to 'white' cable from CABIN SIGNALLING MODULE.

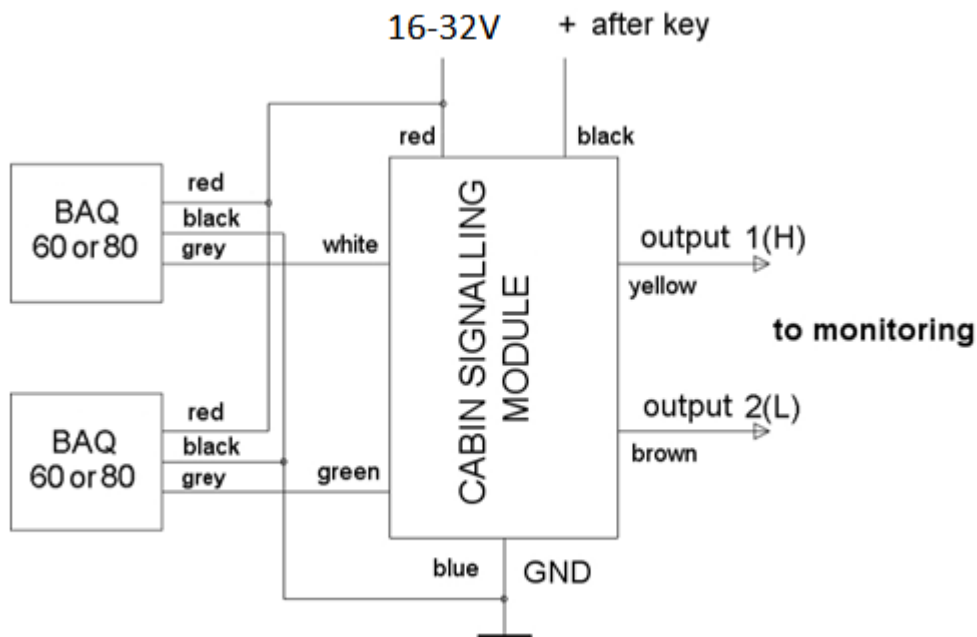

Figure 4. Two tanks connection scheme.

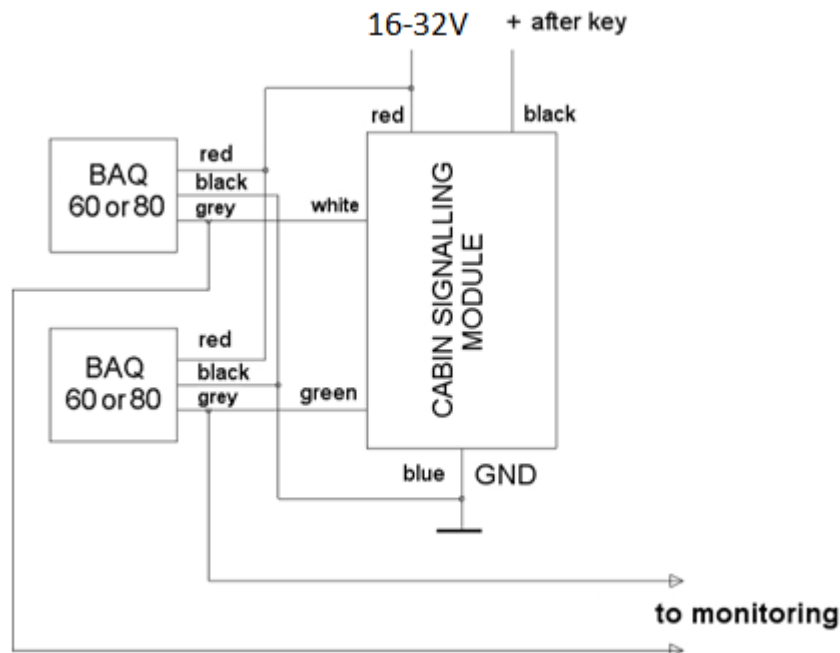

Figure 5. Two tanks with PLUG MODULE identification.

Safety measures.

All operation (inspection, checks) must be performed after studying carefully the Installation manual. Before performing any connection operation, disconnect electrical power from the device.

Operation Manual

After having been mounted, the system does not require operation, except resetting the ALARM and closing the plug. To do this, the driver should turn off the ignition lock.

Normal operation

Once power has been connected, the system is ready to work.

When the plug is closed:

- PLUG MODULE output indicates high status, equal to power voltage
- CABIN SIGNALING MODULE output 1 indicates high status, equal to power voltage
- CABIN SIGNALING MODULE output 2 indicates low status

When the plug is open:

- PLUG MODULE output indicates low status
- CABIN SIGNALING MODULE output 1 indicates low status
- CABIN SIGNALING MODULE output 2 indicates high status, equal to power voltage

When the PLUG MODULE cable has been cut (sabotage):

- CABIN SIGNALING MODULE output 1 indicates low status
- CABIN SIGNALING MODULE output 2 indicates high status, equal to power voltage

A beeping signal in the cabin.

Opening the plug or cutting the cable from BAQ 60/80 when the ignition lock is turned on will trigger a beeping sound and activate a LED diode in the cabin. After closing the plug, CABIN SIGNALING MODULE enters the ALARM MEMORY mode, the LED diode flashes and there is no beeping sound. After the key in the ignition has been turned, the device enters basic mode.
SILENT OPENING – the ignition is left on, there is no beeping sound while refueling.

Programming.

The user cannot program new fuel filler plugs. If necessary, please contact the supplier (company Technobaltica www.technobaltica.com). The interference and actions of reprogramming the RFID tag in the head of the device leads to the immediate termination of the warranty.

Maintenance

If the system is mounted properly, it does not require any maintenance operation for a period of 2 years. After that, check the insulation of PLUG MODULE cable.

In order to prevent the plug or the locking mechanism from being damaged mechanically, keep the plug clean and remember to close the cover of the locking mechanism. Do not lubricate or pour diesel fuel on it.

STORAGE AND TRANSPORTATION

Storage

BAQ 60/80 must be stored in their original packaging in a closed area, free from corrosive agents, in temperatures from 0°C to 70°C, with relative humidity no higher than 80%. Ensure anti-shock and anti-vibration protection.

Transportation

Transportation of BAQ 60/80 should be performed with a covered-top means of transport. The packaging should be protected against movement.

ACCESSORIES

Anti-siphon strainer

The anti-theft strainer is a pipe with perforated walls and bottom. The shape of the bottom and size of holes have been fitted so as not obstruct the filling operation while protecting against theft.

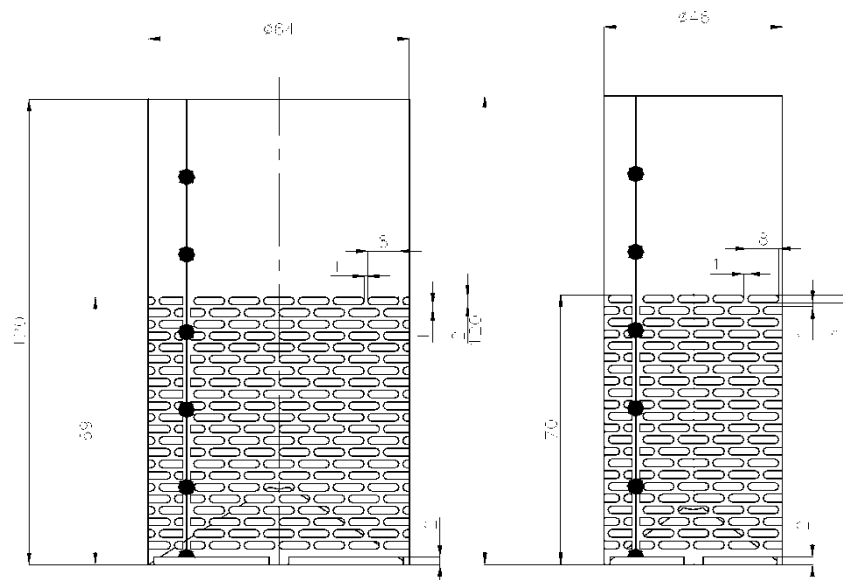

Figure 6. BAQ 80/60 anti-theft strainer dimensions.

General view



Plug module



Appendix C

Anti-siphon strainer



Cabin signaling module.

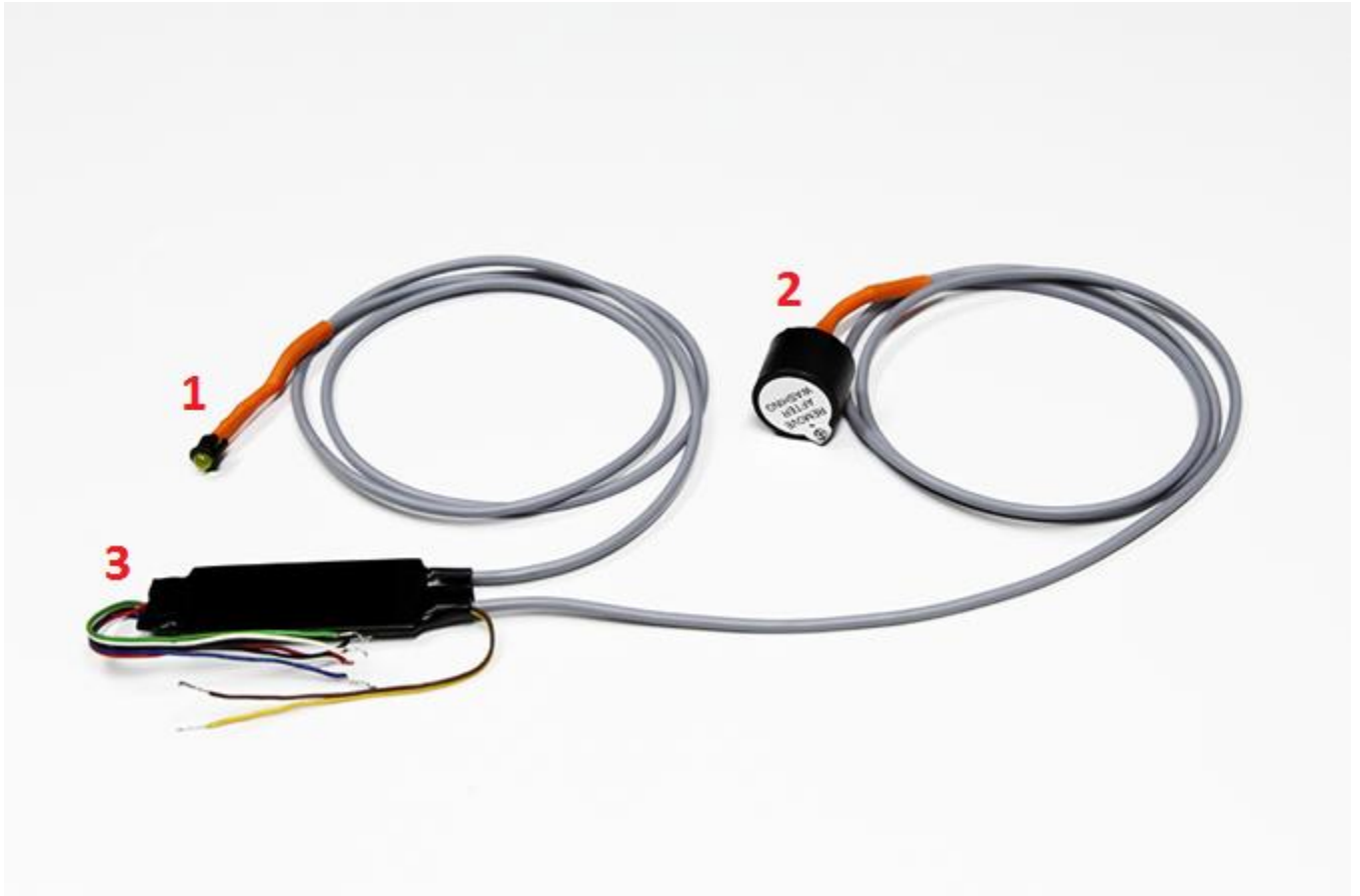

- 1 - Signal LED
- 2 - Buzzer
- 3 - Signaling module

REVISION HISTORY

Date	Version	Description
16.01.17	1.4	Initial Release
12.02.17	1.5	Changed logo